

THIS DRAWING IS UNPUBLISHED. RELEASED FOR PUBLICATION
 © COPYRIGHT - By - ALL RIGHTS RESERVED.

LOC	DIST	REVISIONS					
AJ	16	P	LTR	DESCRIPTION	DATE	DWN	APVD
			A1	REVISED PER ECO-11-005030	11MAR11	RK	HMR

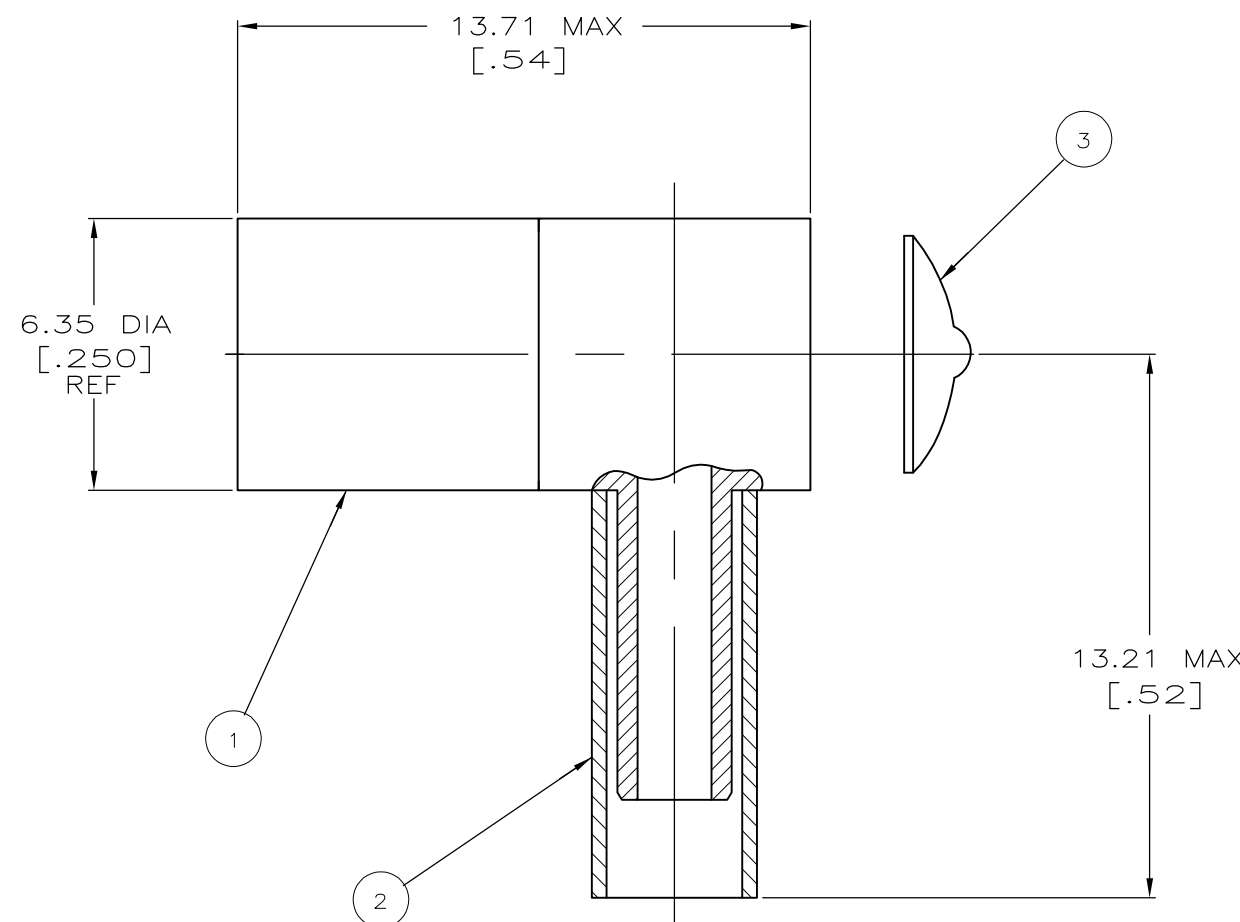

1. INTERFACE PER MIL-C-39012.
2. SEE INSTRUCTION SHEET 408-2987-9.

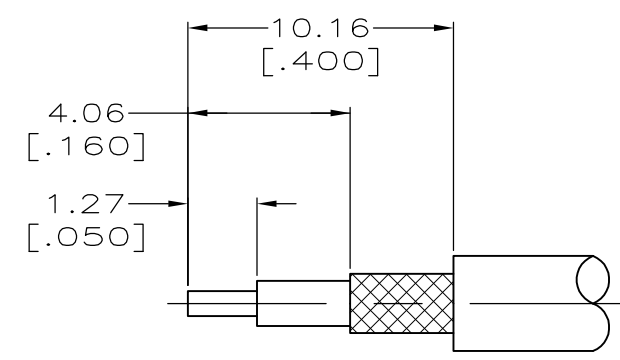

A	58483-1	.105	HX4-1637	414013-3	1-413889-5	9-414364-2	RG 178,196	5414363-8
B	58483-1	.128	HX4-1637	414013-3	1-413889-3	9-414364-1	RG 174,188,316	5414363-5
C	58483-1	.151	HX4-1637	414013-3	1-413889-4	9-414364-0	RG 174,188,316(ALL DBL SHIELDED)	5414363-4
B	58483-1	.128	HX4-1637	414013-3	1-413889-3	9-414364-0	RG 174,188,316	5414363-3
POSITION LETTER	AMP DIE SET	HEX SIZE	DANIELS DIE SET	③ END CAP QTY=1	② FERRULE QTY=1	① PLUG ASSY QTY=1	CABLE	PART NO
	PRO-CRIMPER FOR BRAID CRIMP	M 22520/5-01 FOR BRAID CRIMP						

TOOLING INFORMATION		THIS DRAWING IS A CONTROLLED DOCUMENT.		DWN J. HAVENER 23MAR2005		STE TE Connectivity	
				CHK J. HAVENER 23MAR2005			
DIMENSIONS: mm [INCHES]		TOLERANCES UNLESS OTHERWISE SPECIFIED:		APVD J. HAVENER 23MAR2005		NAME	
		0 PLC ± -		PRODUCT SPEC		PLUG,RTANG CRIMP,HEX CRIMP,SMB	
		1 PLC ± -		-		APPLICATION SPEC	
		2 PLC ± 0.25 [.010]		-		SIZE	
		3 PLC ± 0.130 [.005]		-		CAGE CODE	
		4 PLC ± -		-		DRAWING NO	
		ANGLES ± 1°		-		RESTRICTED TO	
MATERIAL		FINISH		WEIGHT		A3 00779 C-5414363	
-		-		-		SCALE 8:1 SHEET 1 OF 1 REV A1	